



## NEW - SKL 1500

Screw compressor

**CVS develops and manufactures compressors specifically designed for installation in trucks. The development is made in close collaboration with our customers. This guarantees the optimum product for your application.**

### The oil free screw compressor

The oil free screw compressor SKL 1500 was developed specifically for the bulk tanker industry.



### Features

- » High standard of build quality.
- » Unique and robust design guarantee long lasting performance and high operating hours.
- » Compact and light-weight design for increased payloads.

### Screw compressors with system

The volume flow rate of the SKL 1500 ranges from 770 up to 1640 m<sup>3</sup>/h at input drive speeds of 1000 up to 2000 rpm. The newly developed design of screw ensures increased efficiency and low discharge air temperatures with low noise operation.



### Advantages

- » High volume flow while maintaining a high pressure possible.
- » High quality robust design guarantees long lasting performance and longer operating life.
- » Low weight.
- » Extensive speed range allows greater flexibility and maximum performance.
- » 2.5 bar operating pressure over full speed range.
- » Compact design for ease of installation.
- » Integrated lubricating oil pump and easy-to-change oil filter.



## Dimensions

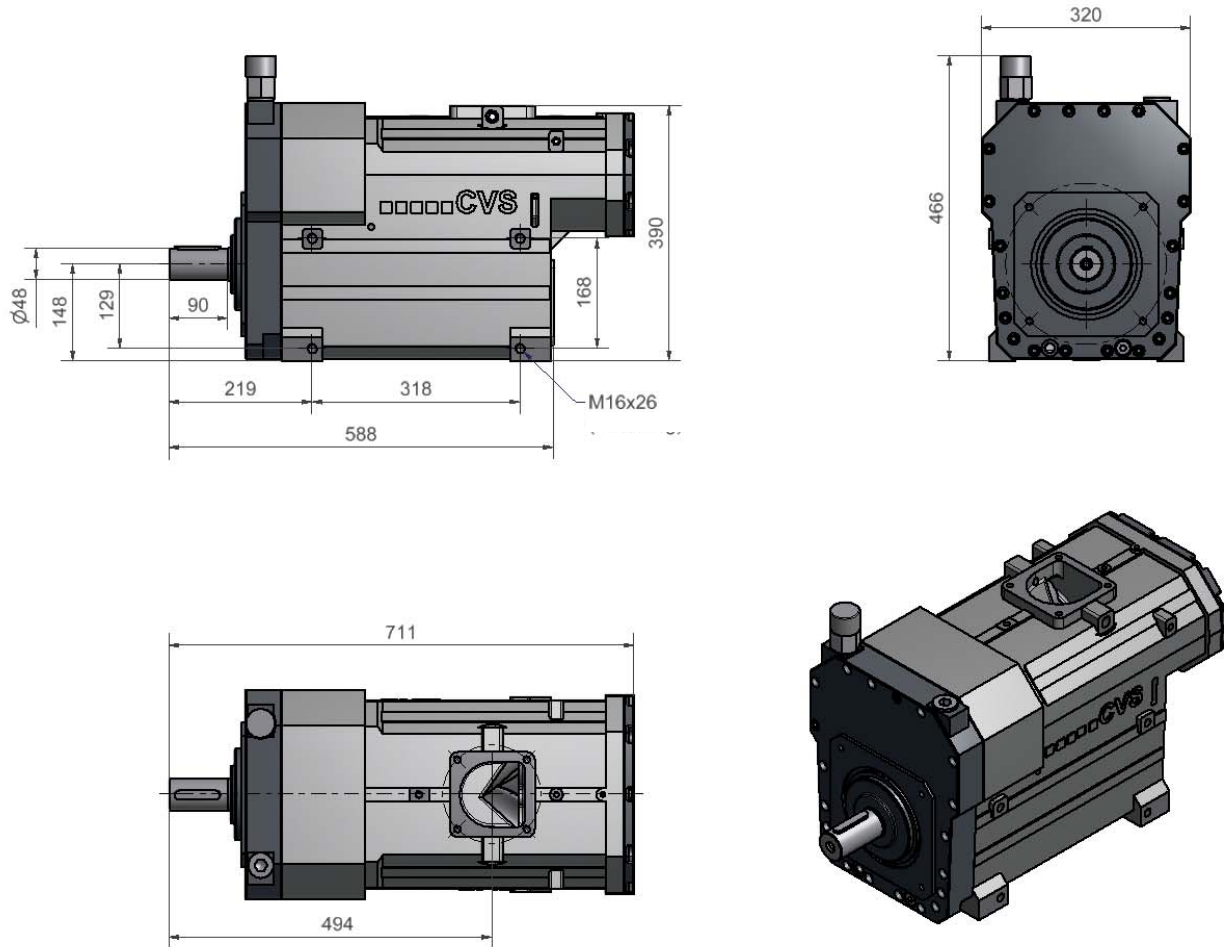

## Technical data

		SKL 1500			
		1000	1400	1600	2000
<b>Speed</b>	<b>rpm</b>	<b>1000</b>	<b>1400</b>	<b>1600</b>	<b>2000</b>
<b>Volume flow at free air</b>	<b>m<sup>3</sup>/h</b>	770	1139	1301	1640
<b>Volume flow at 2 bar g</b>	<b>m<sup>3</sup>/h</b>	690	1063	1217	1560
<b>Max. pressure</b>	<b>bar</b>	2.5	2.5	2.5	2.5
<b>Speed range</b>	<b>1/min</b>	1000 – 2000			
<b>Power requirement at 2 bar</b>	<b>kW</b>	41.0	57.5	66.0	85.0
<b>Weight</b>	<b>kg</b>	185			

Technical information subject to change