

CUSTOMER BULLETIN INFORMATION

REPLACEMENT OF THE OIL FILTER FT6035 BY FT6035A

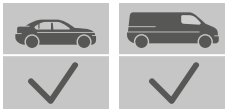

NEW OIL FILTER REFERENCE: FT6035A

The spin-on filter FT6035 has a special design: it's mounted upside down and includes a specific clean servicing valve.

A spring located inside the clean servicing valve maintains its position on the anti-drain back plate, then providing a seal when the filter is mounted properly. This valve opens the drain when the filter is loosened during the oil change.

In order to follow the specification of the latest OE designs, **CoopersFiaam** is replacing FT6035 by **FT6035A**.

This new filter and related modification of the clean servicing valve allows the fitment on the 3 following engines codes and vehicles: Audi, Seat, Skoda, Volkswagen (CBZA, CBZB, CAXA).

OE / COOPERSFIAAM FILTERS:

Volkswagen group and competitors offers 2 filters corresponding to FT6035A:

OE 03C 115 561 H, OE 03C 115 561 J.

Those 2 filters are **really similar**: same diameter, height, ... and the clean servicing valve.

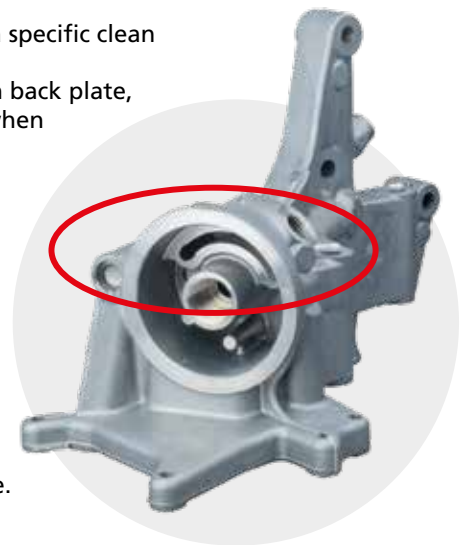

The difference is **the seal**, which has a more complex design on OE 03C 115 561 H. This seal cover the outlets of the valve and prevents loss of oil when removing the filter.

On the CoopersFiaam filter, the design of the clean servicing valve is different and does not need this specific seal, as the valve does not have big holes but small holes for the clips; which means only 1 oil filter replaces the 2 OE filters.



TECHNICAL TIP

- On the OE and some competitor filters, the clean servicing valve includes a separated seal which can stick to the flange and cause oil leakage when fitting the new filter. When servicing, check carefully for this possible old seal removal.
- It is very important to lubricate the two seals with clean engine oil before assembly: the square seal and the valve seal.

PI2021 07

DOWNLOAD
OUR APP!



www.coopersfiaam.com

soGefi GROUP